

Belt Misalignment Monitoring of Bucket Elevators

SBW

Leaflet No. Kiepe 217



APPLICATION

Kiepe Belt Misalignment Switches SBW are used in bucket elevator installations for monitoring the true tracking of the elevators belt. The switches will operate if the belt exceeds the permissible deviation from the nominal tracking. The switch's output signal energizes the connected control units to stop the elevator in order to avoid spillage of material, severe damage and serious downtime.

Operation

The monitoring of the true tracking of the buckets is realized by mounting a pair of inductive proximity switches near the headpulley on the carrying side and another pair located near the tailpulley on the return side. Misalignment of the buckets becomes detected as soon as a bucket mistracks into the sensing zone of the proximity switch.

The sensing distance of the inductive proximity switches is adjustable by means of a potentiometer accessible from the sensor's surface. A LED indicates when the sensor's oscillator field is interfered by a bucket. All switches can be programmed from NO to NC.

TECHNICAL DATA

Device complies with	IEC 947-1 EN 50081-1 EN 50082-2
Mounting	Non-flush mounting
Operating voltage	DC-Version: 15 ... 60 V AC-Version: 20 ... 250 V
Load current	400 mA
Surge current	4 A (AC-type)
Minimum load current	8 mA (AC-type)
Hysteresis	< 10 % s_n
Ambient temperature	-20 °C ... +70 °C
Protection	IP 67
Switching frequency	AC: 25 Hz, DC: 100 Hz
Connecting cable	DC: 3 x 0.50 mm ² , length: approx. 2 m AC: 2 x 0.75 mm ² , length: approx. 2 m
Output circuit	DC - PNP - NC/NO-programmable AC - NC/NO-programmable

SELECTION TABLE

Type	s_n (mm)	Adjustable range	DC	AC	Min. diameter of the hole	Order Number
SBW 001	55	10 ... 80 mm	x		160 mm Ø	94.046 510.001
SBW 051	55	10 ... 80 mm		x	160 mm Ø	94.046 510.051
Mounting plate required for type SBW 001/051						96.048 808.001
SBW 002	70	10 ... 110 mm	x		250 mm Ø	94.046 510.002
SBW 052	70	10 ... 110 mm		x	250 mm Ø	94.046 510.052
Mounting plate for type SBW 002/052, complete with plastic rear cover						96.048 808.002
SBW 003	120	20 ... 150 mm	x		400 mm Ø	94.046 510.003
SBW 053	120	20 ... 150 mm		x	400 mm Ø	94.046 510.053
Mounting plate for type SBW 003/053, complete with plastic rear cover						96.048 808.003

s_n (mm) = Rated operating distance, related to steel ST37. For other metals a reduction factor must be considered:

V4A: $s_n \times 0,65$ - Al: $s_n \times 0,4$ - Cu: $s_n \times 0,45$ - Ms: $s_n \times 0,6$

Note: The switches types SBW 002/052 and SBW 003/053 may become operated by means of movable metal parts influencing the switch from the side or from the back. To avoid this fault operation we recommend to protect the switch with a plastic cover.

OPERATING MODES

Switches in AC-Mode to fit in relay/contactor-circuits

Up to 4 switches can operate in series when using the NC-mode. The voltage drop of each switch amounts to 6 volts.

Switches in DC-Mode - protected against short-circuits and wrong polarity

Up to 4 switches can operate as well in series when using the NC-mode as in parallel when using the NO-mode. Switches in DC-mode are suitable to fit directly a PLC.

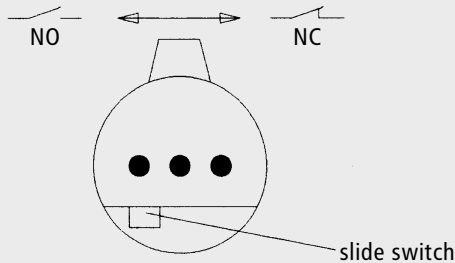

All switches are NO-Preset by factory. To select the NC-mode loose the cable gland and remove the connecting cable. Now the slide switch (see drawing beside) can be moved to the NC-position.

Note:

Exceeding the nominal operating distance s_n will cause an increase of the switching hysteresis and of the sensitivity against metal parts approaching from the back or from the side.

INSTALLATION

The assembly consists of the inductive proximity switches, the connecting cable and a flame resistant mounting plate, together with a gasket, a plastic rear cover and a set of fixing screws.

A hole must be cut in both sides of the chute wall of the bucket elevator. The holes at the headpulley as well as those at the tailpulley should be cut in the travel line of the buckets.

Since the switches are designed for a non-flush mounting a metal-free area should be considered around the switch (please refer to the selection table: min. diam.).

The mounting plates with their gaskets shall be placed on the openings in such a way that they fully cover and seal the holes. The mounting plates are fixed by means of the supplied screws.

For further information please refer to the mounting instructions.

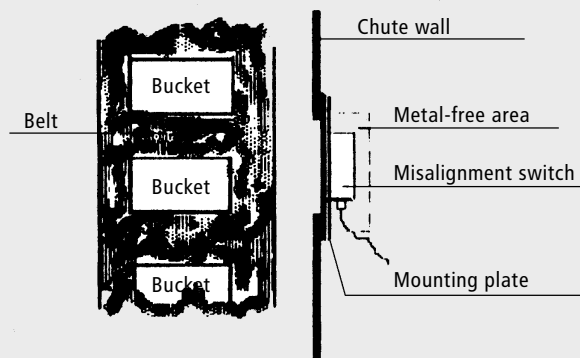

DIMENSIONS

SBW 001/051

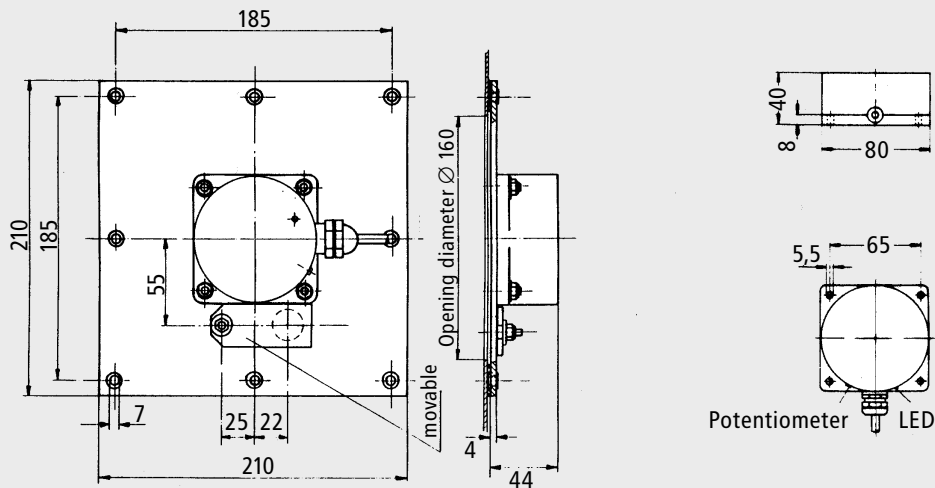

SBW 002/052

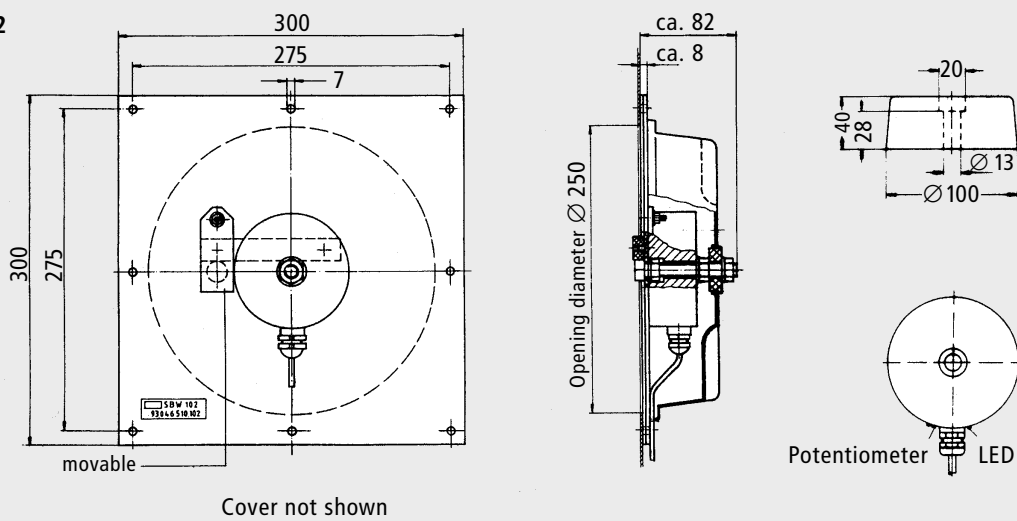

SBW 003/053

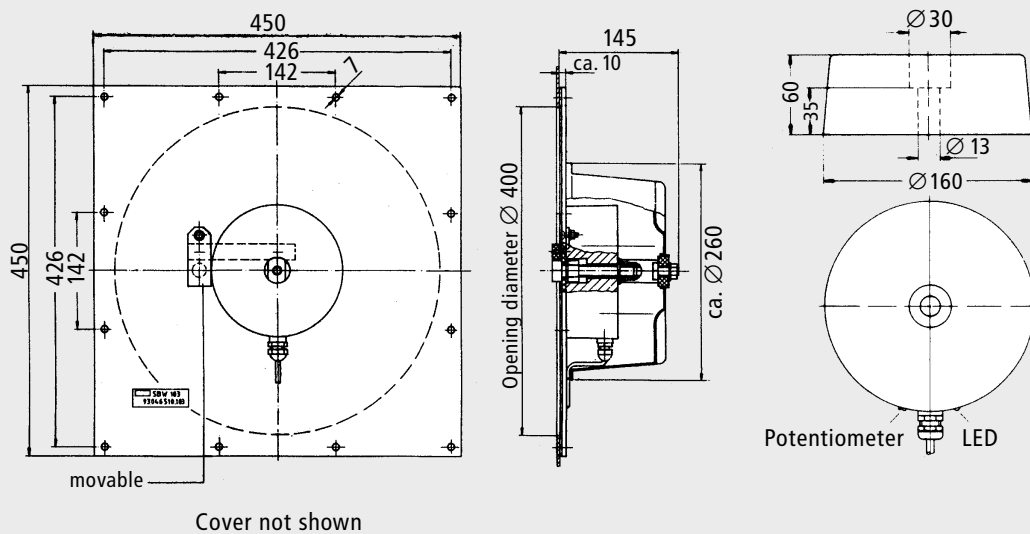

Subject to change without notice.