

Conveyor Belt Misalignment Switch

SLS

Leaflet No. **Kiepe 640**



APPLICATION

KIEPE belt misalignment switches of the SLS type are designed for heavy duty application and used at fixed belt conveyors according to DIN EN 620 requirements in order to keep the risk of unintentional operation as low as possible. The lateral movement of the conveyor belt is monitored and by switching off the conveyor in the case of unacceptable belt drift, the belt monitoring prevents damage and destruction of the belt and the machine.

Misalignment Switches are allocated in pairs on both sides at the carrying belt and return belt. The total number of pairs to be used and their installation points are dependent on construction characteristics such as e.g. horizontal or vertical tensioning stations, single-ended or reversible operation and the length of the belt conveyor. Usually (horizontal tensioning station, single-ended operation, length of up to 30 m) one pair of switches is installed in front of the discharge station at the carrying belt.

OPERATION

Inadmissible belt drift occurs when the belt edge approaches the end of the supporting rollers through lateral movement and surpasses it. Then the actuator of the misalignment switch is operated and displaced. In the case of a displacement of the actuator, the first adjustable switching point is between 5° and 15°, the second between 15° and 35°. The shut-off of the conveyor is carried out optionally with the first or second switching point.

Alternatively, a misalignment warning can be created with the first switching point or a safety switch-off with the second switching point. The actuating roller is equipped with ball-bearings and made of alloyed steel and with a large roll diameter of 48 mm it is resistant to wear and is used for belt speeds of up to 3 m/s and higher.

TECHNICAL DATA

Complies with	EN 60947-5-1
Suited for	Controls and facilities according to EN 60204
Enclosure	Bulk molding compound (BMC) yellow RAL 1004
Mounting	4 oblong holes for M8 screws
Admissible ambient temperature	-25 °C ... +70 °C
Extended temperature range	-40 °C ... +70 °C for SLS 711 model
Protection	IP 65 according to EN 60529
Switching system	2 cam operated snap action changeover contacts SPDT, positive making
Actuator	Roller lever, Ø 48 mm, stainless steel
Switching points	adjustable between 5° ... 15° or 15° ... 35° (standard setting is 2 x 10°)
Displacement of actuator	max. 75°
Rated operating voltage U_e	AC 230 V, DC 230 V
Conventional thermal current I_{th}	6 A
Breaking capacity	AC-15: $U_e = AC 230 V, I_e = 1.5 A$ DC-24V: $T = 2 \dots 3 ms, to 3 A$
Cable entry	threaded hole 2 x M25 x 1.5 1x screwed cable gland M25 x 1.5; sealing area Ø 11mm to Ø 16mm 1x dummy plug M25 x 1.5
Connection cross section	max. 1,5 mm ²
Protective conductor connection	inside enclosure, M4, max. 2.5 mm ²
Contact life	0,5 x 10 ⁶ switching cycles at 100 % I_e
Mechanical life	10 ⁴ switching cycles
Optional	Ventilation duct to avoid condensation

Please note: The switches may be used in control circuits only!

SELECTION TABLE

Type	Contact configuration SPDT	Temperature Range -40 °C ... +70 °C	Order number
SLS 011	2		92.064 251.011
SLS 711	2	x	92.064 251.711

Spares and options

Actuating roller, stainless steel, Ø 48 mm	93.058 650.001
Switch element	220.06.04.01.05
Ventilation duct	580.00.16.01.01

CONNECTION DIAGRAM

Switching elements according to DIN EN 50013

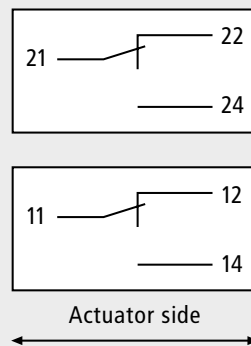

DIMENSIONS

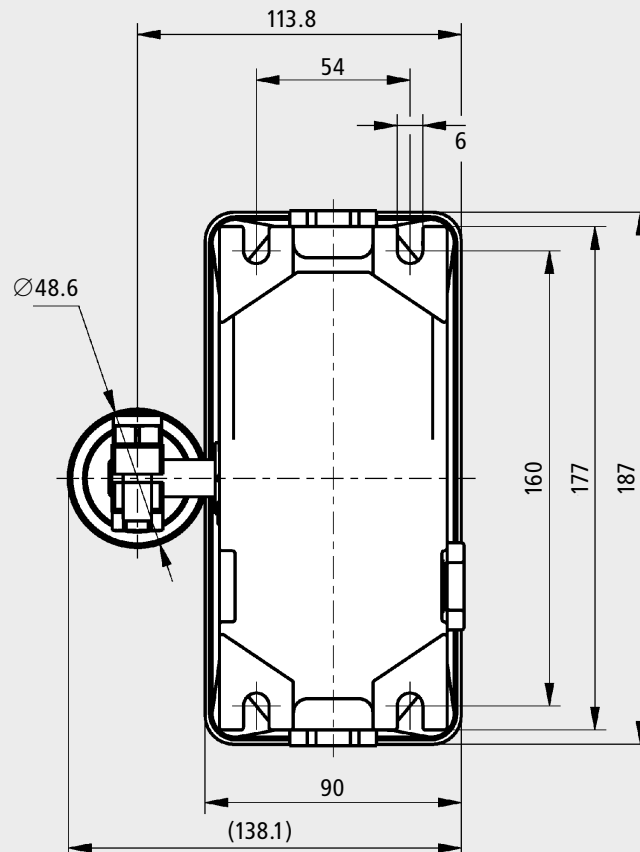

DIMENSIONS

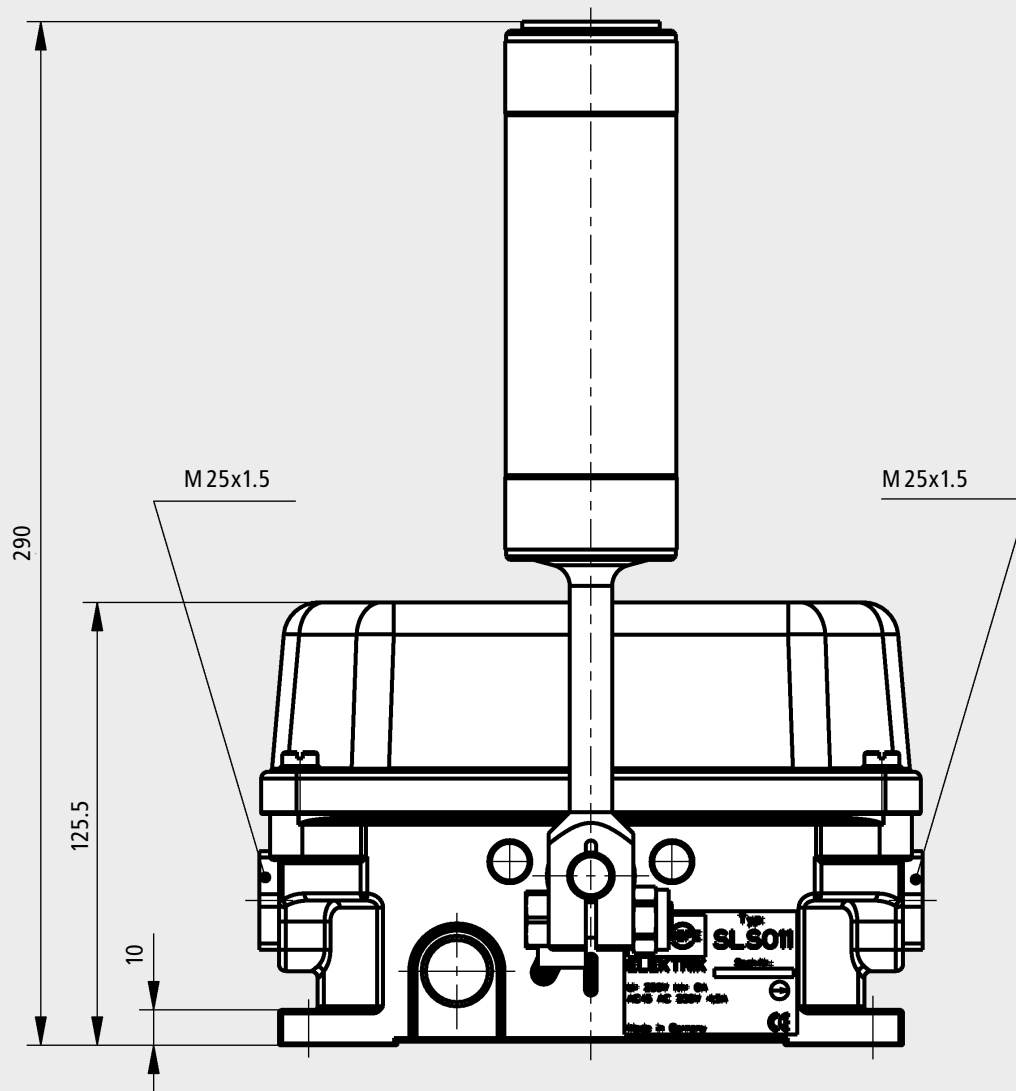

Subject to change without notice.